

Diese Zeichnung darf weder ganz noch teilweise ohne unsere ausdrückliche Genehmigung kopiert oder auf andere Weise vervielfältigt werden. Alle Rechte vorbehalten.
 All rights reserved. All unauthorized copying or reproduction in any form without our express permission is prohibited.

Denne handling får ej uden vårt medgivande delas annan, kopieras eller ej på annat sätt. Detta dokument får ej kopieras eller på annat sätt. Detta dokument får ej kopieras eller på annat sätt. Detta dokument får ej kopieras eller på annat sätt.
 This document must not be copied, either completely or in part, without permission. Any infringement will have legal consequences.

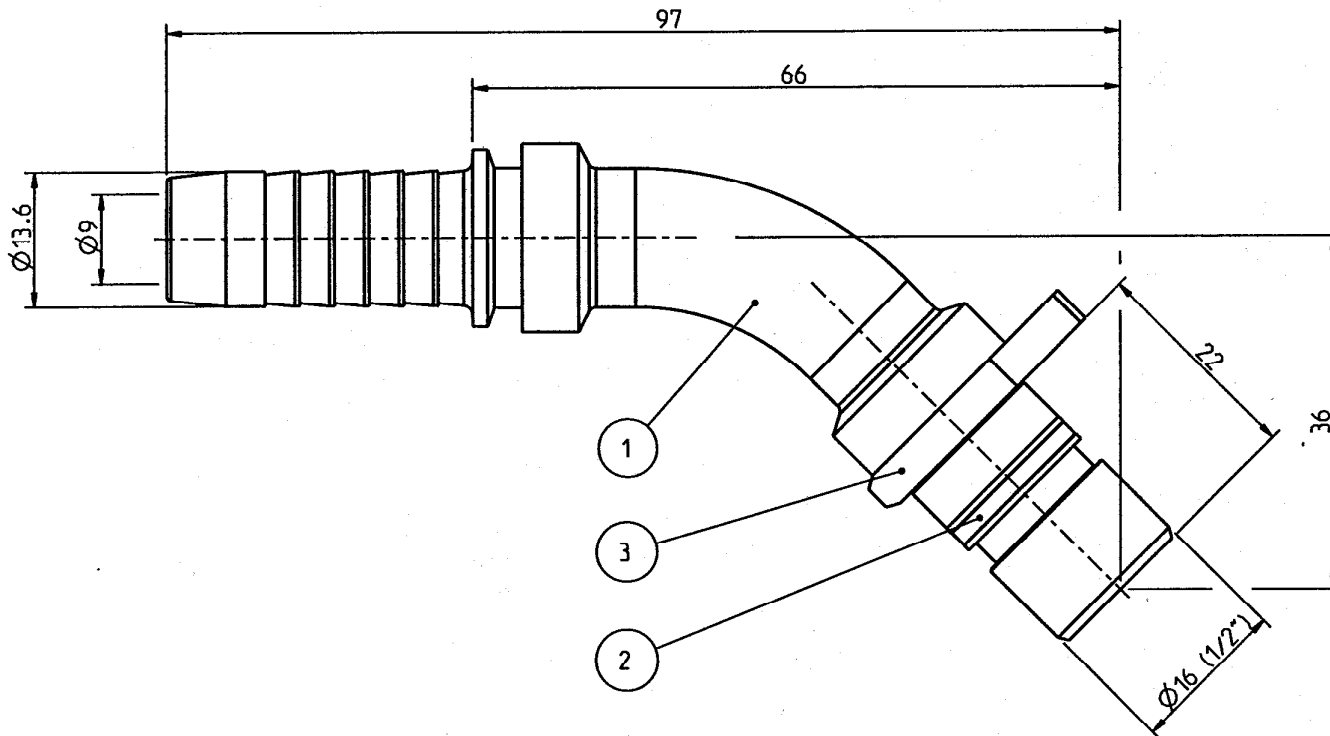

Product No: 14_712_0808

Maximum working pressure: 350 bar
 Minimum burst pressure: 1400 bar

Surface treatment: Yellow zinc chromate plated

Temperature range: -30 °C - +100 °C
 Nominal hole diameter: Ø9 mm
 Connection stroke: 22 mm
 Connection: Hose 1/2" R1/R2 (13.6 mm)

3	1	Assembly stop	POM
2	1	Release ring	POM
1	1	Nipple body	Steel
Detalj Item	Antal Quant.	Benämning Description	Material Material

Cejn Std. kod Cejn Std. spec. Cejn Std. mall	①	②	③	④	⑤	⑥	AN nr. Alt. no. Alt. no.	4649	
Behandling Treatment Behandlung								Am. Den. Den.	
Material Material Werkstoff								Ansprökning Exam. ang. Hergesteltt aus	-
Sharp corner Scale Scale Scale	0.05-0.2	0.05-0.2	0.05-0.2	0.05-0.2	0.05-0.2	0.05-0.2	0.05-0.2	0.05-0.2	0.05-0.2
Skala Scale Måsstab									
Ritad Drawn Bearb.									
Kontroll Checked Geprüft.									
JE									
Godk. Appr. Freigegeben									
MAH									
001212									
Ej toleranssatta mått ang. Unless otherwise specified, tolerances acc. Frei mass toleranzen nach							Produkt nr./Product No./Produkt nr.		
Ritning nr./Drawing No./Zeichnung nr.							50_712_0808		
AA							AA		

50_712_0808 AA
 14_712_0808 AA

